

Generation of a continuous-wave squeezed vacuum state at 1.3 μm by employing a home-made all-solid-state laser as pump source*

Zheng Yao-Hui(郑耀辉)[†], Wu Zhi-Qiang(邬志强), Huo Mei-Ru(霍美茹), and Zhou Hai-Jun(周海军)

State Key Laboratory of Quantum Optics and Quantum Optics Devices, Institute of Opto-Electronics, Shanxi University, Taiyuan 030006, China

(Received 14 January 2013; revised manuscript received 18 March 2013)

We present a continuous-wave squeezed vacuum generation system at a telecommunication wavelength of 1.3 μm . By employing a home-made single-frequency Nd:YVO₄ laser with dual wavelength outputs as the pump source, via an optical parametric oscillator based on periodically poled KTP, a squeezed vacuum of 6.1 dB \pm 0.1 dB below the shot noise limit at 1342 nm is experimentally measured. This system could be utilized for demonstrating practical quantum information networks.

Keywords: squeezed vacuum, telecommunication wavelength of 1.3 μm , optical parametric oscillator

PACS: 42.50.Dv, 42.50.Lc, 42.65.Yj

DOI: 10.1088/1674-1056/22/9/094206

1. Introduction

Due to their low quantum noise, squeezed states can improve the sensitivity of laser interferometers for the detection of gravitational waves.^[1,2] At the same time, they can be also used to construct entangled states of light,^[3–5] which are crucial resources for secure quantum key distribution, for the generation of cluster states for quantum computing,^[6] and for quantum information networks.^[7–9] For any application of the squeezed states of light, mapping and transferring a squeezed state are two critical tasks not only for quantum information but also for ultra-precise optical measurement, since the quantum nature is very susceptible to optical loss. So squeezed states at atom transition and telecommunication (1.5 μm and 1.3 μm) wavelengths are particularly useful.

Continuous variable optical parametric oscillators (CV-OPO) are one of the most efficient devices for the generation of a non-classical state of light. Ever since the first experimental demonstration of squeezed light succeeded in 1985,^[10] many dedicated studies have been developed based on the OPO over the last twenty-seven years. Recently, a factor of 9-dB^[11] and 10-dB^[12] quantum noise squeezing of a laser field were observed by the University of Tokyo and the Max-Planck Institute of Germany, respectively. By utilizing periodically poled LiNbO₃ (PPLN) and periodically poled potassium titanyl phosphate (PPKTP) crystals, squeezed vacuum states have already been generated resonantly at the cesium^[13] and rubidium^[14] lines, respectively. Recently, continuous wave squeezed vacuum states at 1.5 μm were generated by an OPO, and a factor of 2.3-dB, 3-dB, and 5.3-dB non-classical vacuum noise suppression were measured based on PPLN and PPKTP.^[15–17] Although the absorption losses in fibers for 1.5- μm light are less than for 1.3 μm , the phase diffusion effect of

1.3- μm light is much smaller than that of 1.5 μm . The phase diffusion of light will strongly increase phase noise, which is disadvantageous to quantum information systems. So it is necessary to prepare the squeezed state at 1.3 μm wave band. However, until now, the experimental generation of continuous wave squeezed light at 1.3 μm wave band has not yet been effectively demonstrated.

In this paper, we present a continuous-wave (CW) squeezed vacuum state generation system at a telecommunication wavelength of 1.3 μm based on an OPO containing a PPKTP crystal. The pump source of the OPO is a single-frequency Nd:YVO₄ laser with dual wavelength outputs, including fundamental wave (1342 nm) and harmonic wave (671 nm). The harmonic wave is used as the pump light, and the fundamental wave is used as the signal and the local light. Through a sub-threshold parametric down-conversion process in the OPO, a squeezed vacuum of 6.1 dB \pm 0.1 dB below the shot noise limit (SNL) at 1342 nm is experimentally measured. To the best of our knowledge, it is the highest squeezing at the 1.3- μm wave band.

2. Basic principle

The quantum noise of the OPO leads to the following analytic expression of the squeezing:^[18]

$$V^+(\Omega) = 1 - \eta_{\text{esc}} \eta_{\text{det}} \eta_{\text{hom}} \frac{4\sqrt{P/P_{\text{thr}}}}{(\Omega/\gamma)^2 + \left(1 + \sqrt{P/P_{\text{thr}}}\right)^2}, \quad (1)$$

where η_{esc} is the escape efficiency of the OPO system; η_{det} is the quantum efficiency of detectors; η_{hom} is the homodyne efficiency (related to the square of fringe visibility between the

*Project supported by the National Basic Research Program of China (Grant No. 2010CB923101), the National Natural Science Foundation of China (Grant Nos. 61008001 and 61227015), and the Natural Science Foundation of Shanxi Province, China (Grant No. 2011021003-2).

[†]Corresponding author. E-mail: yhzheng@sxu.edu.cn

signal beam and local oscillator (LO)); P and P_{thr} are the pump and threshold powers, respectively.

From expression (1) it follows that the high escape, quantum and homodyne efficiency are of benefit to the enhancement of the quality of squeezing. The quantum efficiency is limited by detectors (ETX-500 photodiode), which cannot be improved by optimizing the OPO system. In our setup, the fringe visibility is observed to be 98% corresponding to the homodyne efficiency of 96%. It is quite difficult to further improve the homodyne efficiency. So the increase of the escape efficiency of the OPO cavity is the most effective method of reducing the quantum noise. The escape efficiency of the OPO is the ratio of output coupling transmissivity to the total cavity loss. Obviously, the escape efficiency can be increased by reducing the reflectivity of the output mirror of the OPO. However, this is at the expense of a quadratic increase in threshold power. Thus a further increase in escape efficiency is only feasible with a more powerful pump laser. Therefore, we employ a recently developed powerful single-frequency laser with dual wavelength outputs, capable of emitting up to 2.8 W at 671 nm.^[19]

3. Experimental setup

The schematic of the squeezed vacuum generation system is shown in Fig. 1. The laser is a CW intra-cavity frequency-doubled Nd:YVO₄/LBO (neodymium doped yttrium orthovanadate/LiB₃O₅) laser. The harmonic wave of

2.8 W at 671 nm and the fundamental wave of 0.85 W at 1342 nm are generated simultaneously from the laser.^[19] The output red and infrared lasers are separated by a dichroic beam splitter (DBS) coated with high reflectivity for 671 nm and high transmission for 1342 nm, and then are used as the pump field and the local light of balance homodyne detection, respectively. Two traveling-wave resonators placed in the laser beam of 1342 nm and 671 nm serve as the optical low-pass filter of noise and the spatial mode cleaner (MCI and MCR). The finesse and the linewidth of MCI for 1342 nm are 300 and 2 MHz, respectively, which is also used as a frequency standard to stabilize the laser frequency, via its transmission signal feed back to the laser. The finesse and the linewidth of MCR for 671 nm are 400 and 1.5 MHz, respectively, which can not only significantly improve the quality of spatial distribution of pump beam, but also can reduce the noise to SNL at a frequency of more than 1.5 MHz. The improvement benefits the improvement on the quality of squeezed vacuum. MCR is adjusted to resonate with the harmonic field via a Pound–Drever–Hall locking scheme with a phase modulation frequency of 44 MHz.^[20] The transmission of MCR for 671 nm is about 70%. Taking the transfer loss into account, the pump power is capable of reaching 1.3 W in front of the OPO. The power is far more than the threshold of the present OPO, which not only meets the requirements for one OPO in present experiment, but also provides enough power for pumping more OPOs simultaneously, whose aim is to develop the quantum information network in future work.

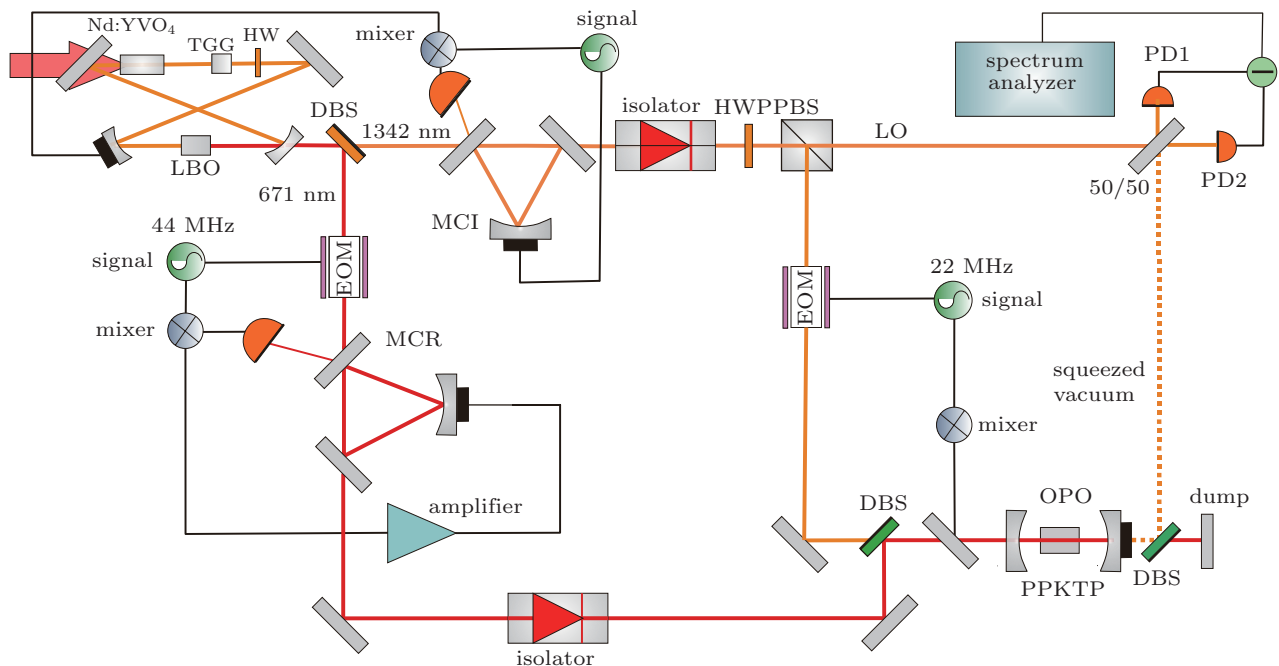

Fig. 1. (color online) Schematic of the experimental setup. PBS: Polarization Beam Splitter; EOM: Electro-Optical Modulator; OPO: Optical Parametric Oscillator; PD: Photodiode; DBS: Dichroic Beam Splitter; HWP: Half Wave plate; LO: Local Oscillator; MCI: Mode Cleaner of 1342 nm; MCR: Mode Cleaner of 671 nm.

Our squeezed light source is composed of two concave mirrors each with a curvature radius of 50 mm and a PPKTP crystal via type-I optical parametric oscillation. The effective cavity length of the OPO is 103 mm and the beam waist radius of the fundamental wave in the crystal is about 58 μm . Taking the refractive index of 1.73 into account, this results in a cavity free spectral range of approximately 1.32 GHz and a cavity linewidth of 25 MHz. The OPO cavity is designed to make the down-conversion light at 1342-nm resonate in the optical cavity and the pump light at 671 nm only double pass. The input coupling mirror of the OPO is of high reflectivity at 1342 nm ($R > 99.8\%$) and of high transmission at 671 nm ($T = 95.2\%$). The squeezed output wave is extracted from another concave mirror with partial transmission at 1342 nm ($T = 10\%$) and with high reflectivity at 671 nm ($R > 99.8\%$). The mirror is mounted on a piezoelectric transducer (PZT) to control the cavity length on resonance for signal beam. The PPKTP crystal is antireflectivity coated at both 1342 nm and 671 nm with dimensions of 1 mm (thickness), 3 mm (width), and 15 mm (length). The poled period of the PPKTP crystal is 52 μm in length, which is controlled at a phase matching temperature of 40° by a specially designed device with a temperature control accuracy of 0.01° . The setting precision of the temperature controller is 0.002° by using a novel bridge circuit which can ensure optimal working temperature of the PPKTP crystal. The threshold power and parametric gain of the OPO are 362 mW and more than 1000, respectively. Through a parametric down conversion process, a squeezed vacuum can be produced, which leaves the OPO from the output coupler and is separated via a dichroic beam splitter (DBS). The (squeezed) quantum noise is observed by means of a balance homodyne detector and consists of a 50/50 splitter and a pair of Epitaxx ETX-500 photodiodes with a quantum efficiency of 92% or so. The squeezed vacuum is combined with a local oscillator to interfere on the 50/50 splitter. A piezo-actuated steering mirror is employed to shift the local oscillator phase relative to the squeezed field. To adjust the visibility of interference fringe, we lock the OPO cavity length and achieve the transmitted light in advance, which can be used to interfere with the local oscillator on the 50/50 beam splitter. The fringe visibility is 98% and achieved by careful mode matching. The beam parameter of the transmitted light is the same as that of the squeezed vacuum, which is employed as the auxiliary beam of adjusting the interference. The two outputs from the 50/50 beam splitter are each focused and detected by a pair of ETX-500 photodiodes with a quantum efficiency of 92%. The difference current between two photodiodes is fed back to a spectrum analyzer to measure the quantum noise level. The electronic circuit of the homodyne detector is mainly composed of low noise operational amplifier (AH0013), which provides the advantage of extremely low noise for the homo-

dyne detector.

The fundamental wave, transmitted from the MCI, is split into two beams via a half-wave plate (HWP) and a polarized beam splitter (PBS): a local oscillator and a signal beam. The local oscillator is used as an auxiliary beam of balanced homodyne detection. The signal beam has three functions. Firstly, it is injected into the OPO cavity to assist the mode matching between down conversion beam and the OPO. Secondly, it is used for measuring the intracavity loss and the classical parametric gain. Finally, it is employed as an auxiliary beam to check the interference degree between the squeezed vacuum and the local oscillator, by locking the OPO cavity on resonance with the signal beam via a servo loop.

4. Experimental results

To confirm the observed squeezed strength, we check the linearity of the homodyne detection system by measuring the shot-noise levels versus local oscillator power at a sideband frequency of 2 MHz. Figure 2 shows seven measurement values, which are indicated with square marks. Changing the local oscillator power by a factor of two entails a 3-dB shift of the corresponding noise trace, showing that the detector is quantum noise limited and operates linearly in the measurement regime.

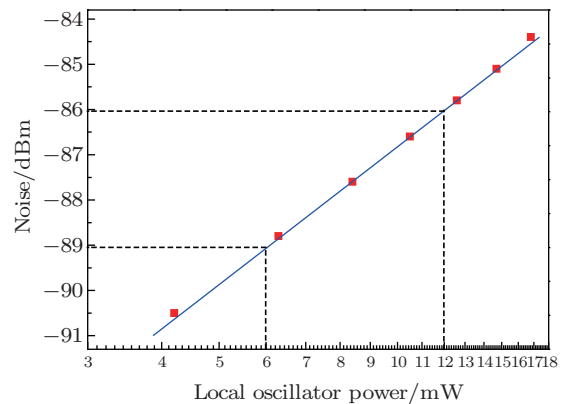

Fig. 2. (color online) Dependence of the noise level on local oscillator power (squares, measured data). Linear fitting to data (solid line) indicates the linearity of the homodyne detection system.

Figure 3 shows the quantum noise levels of the squeezed light at the pump power of 260 mW as the local oscillator phase is being scanned. The noise level is measured with a spectrum analyzer (Agilent MXA Signal Analyzer N9020A with electronics noise of -117 dBm) at the Fourier sideband frequency of 2 MHz, with a resolution bandwidth of 30 kHz and a video bandwidth of 100 Hz. Trace *a* corresponds to the SNL of 12 mW local oscillator power and is measured with the squeezed light input blocked, which corresponds to the quantum mechanical ground state of the light. Trace *b* shows the quantum fluctuations depending on the local oscillator phase, when the squeezed vacuum is injected. The mea-

sured squeezed noise level is $6.1 \text{ dB} \pm 0.1 \text{ dB}$ below the SNL, and the anti-squeezed noise level is $12.9 \text{ dB} \pm 0.2 \text{ dB}$ above the SNL. In the experimental setup, increasing further the pump power cannot enhance the quality of the squeezed noise. However, if there is a higher transmissivity of the output mirror of the OPO, the quality of the squeezed noise can be further reduced at the expense of high pump power.

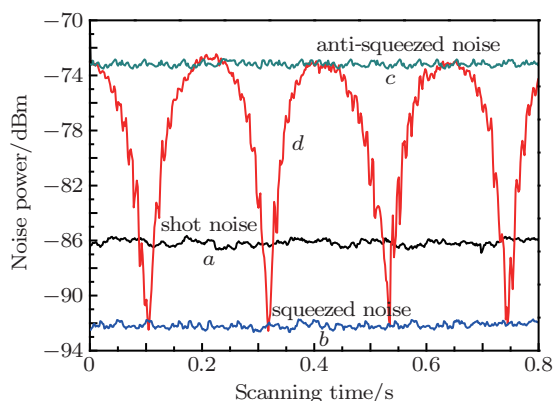

Fig. 3. (color online) Measured quantum noise levels of the squeezed vacuum at a pump power of 260 mW as the local oscillator phase is scanned. The noise level is measured with a spectrum analyzer at the Fourier sideband frequency of 2 MHz, with a resolution bandwidth of 30 kHz and a video bandwidth of 100 Hz. Trace *a* corresponds to the SNL. Traces *b* and *c* represent squeezed and anti-squeezed noise. Trace *d* shows the quantum fluctuations depending on the local oscillator phase, when the squeezed vacuum is injected.

Due to the quantum efficiency of detector, and phase fluctuations between the LO and the squeezed beam, the observed squeezed noise (6.1 dB) is far lower than the anti-squeezed noise (12.9 dB). So the generated state is not a minimum uncertainty state, which is due to the lossy OPO, phase fluctuations, etc. In our future work, further experiments will be carried out to optimize these parameters and increase the transmissivity of the output mirror of the OPO, so a higher squeezed level could be achieved, with the experimental conditions improved.

5. Conclusion

In this paper, we succeed in observing $6.1 \text{ dB} \pm 0.1 \text{ dB}$ of squeezing and $12.9 \text{ dB} \pm 0.2 \text{ dB}$ of anti-squeezing at a telecommunication wavelength of 1342 nm by using a home-made all-

solid-state single-frequency laser as the pump source. Compared with other work, our work demonstrates that the low quantum noise at 1.3- μm wave band can be obtained by using a home-made laser as the pump source. The system conveniently integrates the laser into the OPO and obtains an actual non-classical light generating apparatus. Due to the low loss of 1342 nm wavelength in the fiber, the presented system will be helpful for designing practical quantum telecommunication networks and high precision detection systems.

References

- [1] Goda K, Miyakawa O, Mikhailov E E, Saraf S, Adhikari R, McKenzie K, Ward R, Vass S, Weinstein A J and Mavalvala N 2008 *Nature Phys.* **4** 472
- [2] Vahlbruch H, Chelkowski S, Hage B, Franzen A, Danzmann K and Schnabel R 2006 *Phys. Rev. Lett.* **97** 011101
- [3] Li X Y, Pan Q, Jing J T, Zhang J, Xie C D and Peng K C 2002 *Phys. Rev. Lett.* **88** 047904
- [4] Bowen W P, Treps N, Buchler B C, Schnabel R, Ralph T C, Bachor H A, Symul T and Lam P K 2003 *Phys. Rev. A* **67** 032302
- [5] Wang Y, Shen H, Jin X L, Su X L, Xie C D and Peng K C 2010 *Opt. Express* **18** 6149
- [6] Menicucci N C, Loock P V, Gu M, Weedbrook C, Ralph T C and Nielsen M A 2006 *Phys. Rev. Lett.* **97** 110501
- [7] Ourjoumtsev A, Tualle-Brouiri R, Laurat J and Grangier P 2006 *Science* **312** 83
- [8] Yang R G, Sun H X, Zhang J X and Gao J R 2011 *Chin. Phys. B* **20** 060305
- [9] He G Q, Zhu S W, Guo H B and Zeng G H 2008 *Chin. Phys. B* **17** 1263
- [10] Slusher R E, Hollberg L W, Yurke B, Mertz J C and Valley J F 1985 *Phys. Rev. Lett.* **55** 2409
- [11] Takeno Y, Yukawa M, Yonezawa H and Furusawa A 2007 *Opt. Express* **15** 4321
- [12] Vahlbruch H, Mehmet M, Chelkowski S, Hage B, Franzen A, Lastzka N, Goßler S, Danzmann K and Schnabel R 2008 *Phys. Rev. Lett.* **100** 033602
- [13] Polzik E S, Carri J and Kimble H J 1992 *Appl. Phys. B* **55** 279
- [14] Tanimura T, Akamatsu D, Yokoi Y, Furusawa A and Kozuma M 2006 *Opt. Lett.* **31** 2344
- [15] Feng J X, Tian X T, Li Y M and Zhang K S 2008 *Appl. Phys. Lett.* **92** 221102
- [16] Liu Q, Feng J X, Li H, Jiao Y C and Zhang K S 2012 *Chin. Phys. B* **21** 104204
- [17] Mehmet M, Steinlechner S, Eberle T, Vahlbruch H, Thüring A, Danzmann K and Schnabel R 2009 *Opt. Lett.* **34** 1060
- [18] Lam P K, Ralph T C, Buchler B C, McClelland D E, Bachor H A and Gao J 1999 *J. Opt. B: Quantum Semiclass. Opt.* **1** 469
- [19] Zheng Y H, Wang Y J, Xie C D and Peng K C 2012 *IEEE J. Quantum Electron.* **48** 67
- [20] Drever R W P, Hall J L, Kowalski F V, Hough J, Ford G M, Munley A J and Ward H 1983 *Appl. Phys. B* **31** 97