

A compact Einstein–Podolsky–Rosen entangled light source*

Wang Ya-Jun(王雅君), Yang Wen-Hai(杨文海), Zheng Yao-Hui(郑耀辉)[†], and Peng Kun-Chi(彭堃堃)

State Key Laboratory of Quantum Optics and Quantum Optics Devices, Institute of Opto-Electronics, Shanxi University, Taiyuan 030006, China

(Received 15 November 2014; revised manuscript received 2 February 2015; published online 18 May 2015)

We present a stable entangled light source that integrates the pump laser, entanglement generator, detectors, and electronic control systems. By optimizing the design of the mechanical elements and the optical path, the size of the source is minimized, and the quantum correlations over 6 dB can be directly provided by the entangled source. The compact and stable entangled light source is suitable for practical applications in quantum information science and technology. The presented protocol provides a useful reference for manufacturing products of bright entangled light sources.

Keywords: compact entangled light source, Bell-state detection

PACS: 03.65.Ud, 03.67.Mn, 07.60.-j

DOI: 10.1088/1674-1056/24/7/070303

1. Introduction

Quantum entanglement is an important resource for quantum communication and quantum computation.^[1–3] A variety of quantum information protocols, including quantum key distribution,^[4,5] entanglement swapping,^[6,7] quantum relays, quantum repeaters,^[8,9] quantum teleportation,^[10–12] and quantum computation,^[2–4] have been experimentally realized. Quantum information science studies are progressing towards practical applications in the real world. The Einstein–Podolsky–Rosen (EPR) entanglement state of light is a necessary resource for implementing quantum information tasks with continuous variables (CVs) of a quantized optical field. Reid and Drummond theoretically proved the possibility of obtaining the EPR entangled state via intracavity frequency down-conversion in the 1980s.^[13] In 1992, the CV EPR entangled light was first generated experimentally by Ou *et al.* with a non-degenerate optical parametric amplifier (NOPA) operating below the oscillation threshold.^[14] Subsequently, scientists around the world experimentally obtained the EPR entangled light with various wavelengths,^[14–20] which were desirable to enhance the correlations of amplitude or/and phase quadrature. So far, CV entangled states with high entanglement degrees over 10 dB^[20] and multipartite CV entangled states used for quantum networks^[3,21,22] have been realized experimentally. To establish practical quantum information systems, we need compact and robust entangled light sources. For gravitational wave detection, scientists in Germany have built a compact and long-term stable setup to generate the squeezed vacuum state of light. The squeezed light source, with a degenerate optical parametric oscillator (DOPO) of a type-I periodically poled potassium titanyl phosphate (PP-KTP) crystal, has a dimension of 1.5 m².^[23,24] To achieve an

entangled light source, the scheme should be larger in size.

EPR entangled states of light can be directly prepared by applying an NOPA involving a type-II noncritical phase-matching crystal.^[3,18,21] To generate an optical entangled state, the two non-degenerate subharmonic waves with orthogonal polarizations have to resonate simultaneously within the NOPA. The double resonance of the two modes is sensitive to any thermal, mechanic, or electronic disturbance, thus a practical entangled light source should have high mechanical and thermal stability. In addition, the entangled light source should have a small size and it should be easy to use. In 2010, our group experimentally demonstrated a 6 dB EPR entangled light.^[21] However, the work, including two narrow-linewidth mode cleaners (MCs) to suppress the laser noise, was finished on an optical table, which did not consider the practical use. Limited by the transmission efficiency of the MCs, we had to use a high-power laser system to obtain enough pump power. The additional locking system of the MCs also made the experimental setup more complex. Thus, the EPR state generation system has some disadvantages, such as large size, high power consumption, and poor stability.

Here, we present a compact entangled light source in which the resonating frequency of the NOPA is stably locked on the signal beam and the temperature of the nonlinear crystal in the NOPA is well-controlled around the phase-matching point. The single-frequency laser, the NOPA cavity, and all other optical and mechanical elements in the entangled light source are minimized and optimized for a stable entangled state operation. The laser output power meets the needs of the NOPA. Our design not only minimizes the laser size and power consumption, but also reduces the laser noise, which makes the inclusion of MCs unnecessary. The total dimen-

*Project supported by the National Natural Science Foundation of China (Grant No. 61227015) and the Program for the Outstanding Innovative Teams of Higher Learning Institutions of Shanxi, China.

[†]Corresponding author. E-mail: yhzheng@sxu.edu.cn

sion, weight, and power consumption of the entangled light source are only 60 cm×50 cm, 30 kg, and 150 W, respectively. We also optimize the design to obtain the shortest optical path from the laser to the NOPA. The shortest optical path weakens the influence of the air disturbance, and improves the stability and repeatability of the system, without reducing the quantum correlation. The bright entangled light beams with quadrature amplitude and phase correlation over 6 dB are produced and the system can operate stably. The source consists of three modules: the pump laser, the entanglement generator, and the entanglement detector. All of the optical elements are fastened on a small breadboard made of duralumin. The present design provides a useful technique reference for constructing a practical entanglement light source.

2. Basic principles of entangled state generation and detection

A simple schematic diagram to analyze the principles of the entanglement generation and detection is shown in Fig. 1. The NOPA is one of the essential optical devices that are used for preparing the squeezed and entangled states of light. When an NOPA with a type-II nonlinear crystal is used and an injected seed wave at the fundamental frequency ω is pumped by an intense optical field a^P at the harmonic frequency 2ω , a pair of bright entangled light beams will be generated through an intracavity frequency down-conversion process.^[25,26] If the intensity of the pump field is below the oscillation threshold of the optical cavity, the NOPA can be operated at the parametric amplification or de-amplification state with different quantum correlations, which corresponds to the relative phase between the pump and seed waves of $2n\pi$ or $(2n + 1)\pi$ (n is an integer), respectively.^[26] The quantum correlations can be directly measured by Bell-state detection (self-homodyne detection) without the need for a local oscillator in the usual balance homodyne detection when the NOPA is operated at the de-amplification state.^[25] Thus, to simplify the configuration of entangled light generation, the present light source is designed to provide entangled optical beams with anticorrelated amplitudes and correlated phases under de-amplification. In the type-II nonlinear crystal, the injected seed wave a^{in} will be decomposed to signal a_1^{in} and idler a_2^{in} modes with identical frequency but orthogonal polarizations. The input-output equations between the amplitude and the phase quadrature of the input seed wave and the output subharmonic field are expressed as^[13,26]

$$\begin{aligned} X_1 &= X_1^{\text{in}} \cosh(r) - X_2^{\text{in}} \sinh(r), \\ Y_1 &= Y_1^{\text{in}} \cosh(r) + Y_2^{\text{in}} \sinh(r), \\ X_2 &= X_2^{\text{in}} \cosh(r) - X_1^{\text{in}} \sinh(r), \end{aligned}$$

$$Y_2 = Y_2^{\text{in}} \cosh(r) + Y_1^{\text{in}} \sinh(r), \quad (1)$$

where X_1^{in} (X_2^{in}) and Y_1^{in} (Y_2^{in}) are the amplitude and the phase quadrature of the input signal (idler) mode, respectively; X_1 (X_2) and Y_1 (Y_2) are the amplitude and the phase quadrature of the output signal mode a_1 (idler a_2), respectively; and, r (from 0 to $+\infty$) is the correlation parameter between modes a_1 and a_2 , which depends on the strength and the time of the parametric interaction, and is determined by the length L and the second-order nonlinear coefficient χ^2 of the nonlinear crystal, as well as the power of the pump field. For a given NOPA, r is proportional to the pump power only. The $r = 0$ and $r = +\infty$ correspond to the zero correlation (SNL) and the perfect correlation, respectively. To obtain the possibly maximal correlation, the two modes a_1 and a_2 should be balanced; that is, their intensities and frequencies should be exactly the same. To meet the condition, the intensities of a_1 and a_2 should be equal, and the intracavity losses of the signal and the idler modes should be balanced in the NOPA. We also have to force the signal and the idler modes with the orthogonal polarizations simultaneously resonating in the same optical cavity. Under these conditions, the correlation variances of the amplitude and phase quadrature between a_1 and a_2 can be calculated from Eq. (1) as^[26]

$$\langle \delta^2(X_1 + X_2) \rangle = \langle \delta^2(Y_1 - Y_2) \rangle = 2e^{-2r}, \quad (2)$$

where the variances have been normalized to the short noise limit (SNL). The coupled mode of a_1 and a_2 at $\pm 45^\circ$ polarization is a squeezed state of light with the amplitude-quadrature (for $+45^\circ$) or phase-quadrature (for -45°) squeezing of e^{-2r} .^[16,24] Thus, the designed entanglement source can be also used for a squeezer, if needed.

The output signal and idler modes of the NOPA, a_1 and a_2 , are separated by a polarizing beam splitter (PBS) and then the quantum correlations between them are directly measured by a Bell-state detection system consisting of a $\pi/2$ phase shifter ($\pi/2$ PS), a 50/50 beam splitter (50/50 BS), two photo detectors (D_1 and D_2). The phase of a_1 is shifted by $\pi/2$ by the $\pi/2$ PS. Then, a_1 is combined with a_2 on the 50/50 beam splitter. The two output beams from the beam splitter, c and d , are expressed as^[25]

$$\begin{aligned} c &= \frac{1}{\sqrt{2}}(a_1 + ia_2), \\ d &= \frac{1}{\sqrt{2}}(a_1 - ia_2). \end{aligned} \quad (3)$$

With the upper-case operator $O(t) = o(t)e^{i\omega_0 t}$ at the center frequency ω_0 in the rotating frame, the Fourier transformation $O(\Omega) = 1/\sqrt{2\pi} \int dt O(t) e^{-i\Omega t}$ at the modulation frequency Ω can be obtained.^[25] By consulting Ref. [25], the amplitude and the phase quadrature can be written as

$$X_0(\Omega) = O(\Omega) + O^\dagger(\Omega),$$

$$Y_0(\Omega) = \frac{1}{i} (O(\Omega) - O^\dagger(\Omega)). \quad (4)$$

The beams c and d are detected by photodetectors D_1 and D_2 , respectively, and the normalized photocurrent spectra are^[25]

$$\begin{aligned} i_c &= c^\dagger c = \frac{1}{2} (X_1 + Y_1 - Y_2 + X_2), \\ i_d &= d^\dagger d = \frac{1}{2} (X_1 - Y_1 + Y_2 + X_2). \end{aligned} \quad (5)$$

The sum and the difference of i_c and i_d are equal to

$$\begin{aligned} i_+ &= \frac{1}{\sqrt{2}} (i_c + i_d) = \frac{1}{\sqrt{2}} (X_1 + X_2), \\ i_- &= \frac{1}{\sqrt{2}} (i_c - i_d) = \frac{1}{\sqrt{2}} (Y_1 - Y_2). \end{aligned} \quad (6)$$

As we can see, the sum and the difference photocurrents simply denote the amplitude-quadrature sum and the phase-quadrature difference of a_1 and a_2 . Thus i_+ and i_- can be utilized to measure the quantum correlation of amplitude and phase quadrature.

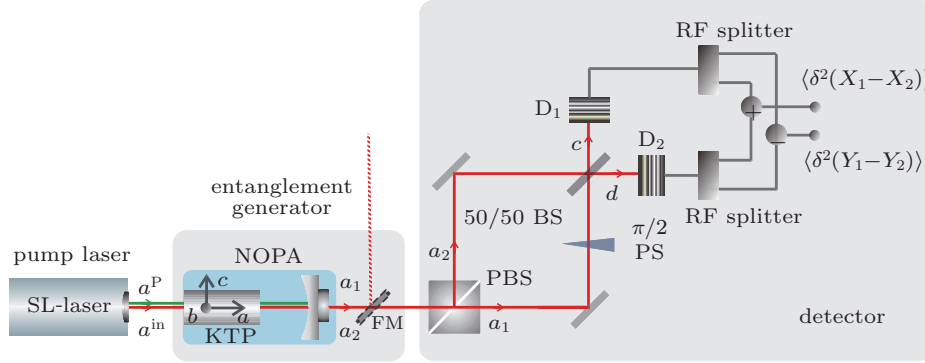

Fig. 1. (color online) Basic principles of entangled state generation and Bell state detection in the state of deamplification of the NOPA. PBS: polarizing beamsplitter; NOPA: nondegenerate optical parameter amplifier; KTP: potassium titanyl phosphate; FM: flip mirror; D_1 , D_2 : detector; SL-laser: single-longitudinal mode laser; RF splitter: radio frequency splitter; $\pi/2$ PS: $\pi/2$ phase shift; 50/50 BS: 50/50 beam splitter.

3. Experimental setup

A schematic diagram of the optical setup for the entangled light source is shown in Fig. 2, which is comprised of three modules: a frequency-stabilized laser, an EPR beam generator, and a Bell-state detection system. At first, we optimize the design to obtain the shortest optical path from the pump laser to the NOPA and the least optical components needed for realizing the optimal mode-matching between the pump laser and the NOPA. This helps to minimize the configuration of the source, weaken the influence of the air distribution, and improve the system performance. All of the optical components, with the laser beam height of 55 mm from the breadboard plane, are fixed on a custom-made breadboard with dimensions of 60 cm \times 50 cm (Fig. 3). The breadboard with a thickness of 15 mm is strengthened by a grid frame to provide a high mechanical stability. The three modules of the EPR light source are described as follows.

The frequency-stabilized laser module consists of a home-made single-frequency Nd:YAP/KTP laser, a high-stability Fabry–Perot (F–P) cavity, and a feedback circuit (laser locking in Fig. 2). The laser directly provides the pump beam at 0.54 μ m and the seed wave at 1.08 μ m for the NOPA. The output powers of the laser at 0.54 μ m and 1.08 μ m are 330 mW and 50 mW, respectively. The laser is especially designed for the entangled light source. The F–P cavity is

employed as both frequency standard and longitudinal-mode monitor. The error signal is detected by a photodetector (PD1), and is fed back via a feedback circuit to the piezoelectric transducer (PZT) that is mounted on one of the laser cavity mirrors that is used to lock the laser frequency to the resonance frequency of the F–P cavity. By means of the active electronic feedback system, the frequency drift of the pump laser is reduced from 60 MHz at free operating state to \sim 500 kHz.

The EPR light beam generation module mainly includes an NOPA and two electronic control circuits, NOPA locking and π phase locking in Fig. 2, which are used to stabilize the length of the optical cavity and the relative phase between the pump laser a^P and the seed wave a_1^{in} and a_2^{in} injected into the NOPA, respectively. The NOPA with semimonolithic configuration consists of an α -cut type-II potassium titanyl phosphate (KTP) crystal of 10 mm long and a concave mirror of 50 mm curvature radius. The front face of the KTP crystal is coated as the input coupler ($T_{0.54} > 95\%$ and $T_{1.08} < 0.5\%$) and the other face is coated with dual-band antireflection at both 0.54 μ m and 1.08 μ m. A concave mirror is used as the output coupler of the EPR beam at 1.08 μ m ($T_{1.08} = 5\%$ and $R_{0.54} > 99.5\%$). The output coupler is mounted on PZT5 to actively lock the cavity length of the NOPA at the double resonance of the signal and idler waves. The total length of the NOPA is about 53 mm. The finesse of the NOPA is about 120 for 1.08 μ m.

The seed wave a^{in} , at 1.08 μ m polarized at the angle of

45° relative to the c axis (in the paper plane) and the b axis (perpendicular to the paper plane, see Fig. 1) of the KTP, is injected into the cavity. Then, a^{in} is decomposed to the input signal and idler waves with identical intensity and orthogonal polarizations along c and b axes, respectively. To compensate for the difference of the optical paths resulting from the KTP birefringence, and to force the signal and the idler waves to doubly resonate inside the optical cavity of the NOPA, we

have to finely tune the temperature of the KTP within its mode-matching range. Once the double resonance of the signal and the idler waves is realized, the temperature of the KTP crystal is kept at that point by an active temperature controller. The length of the optical cavity is also locked on the frequency ω of the injected seed wave by the NOPA locking electronic feedback circuit.

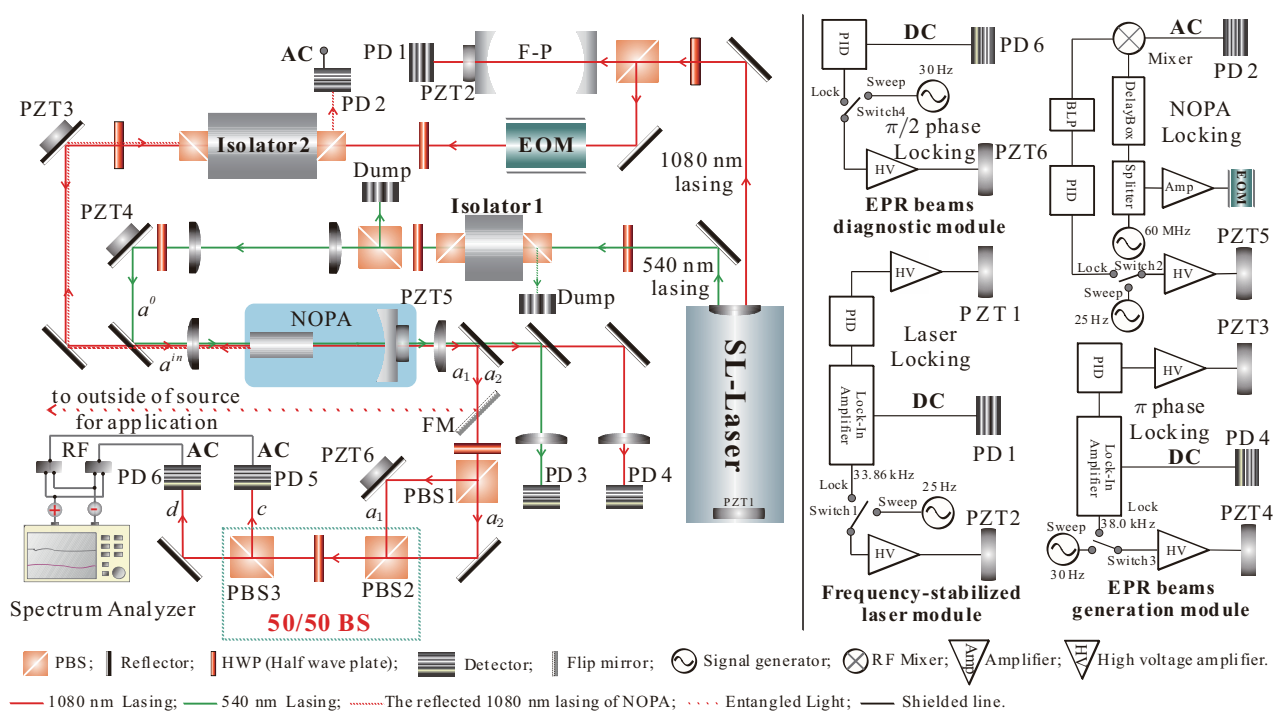

Fig. 2. (color online) Optical and electronic apparatus for the entangled light source. F-P: Fabry–Perot cavity; NOPA: nondegenerate optical parameter amplifier; EOM: electro-optical phase modulator; isolator: optical isolator; PD: photodetector; PZT1-6: piezoelectric transducer.

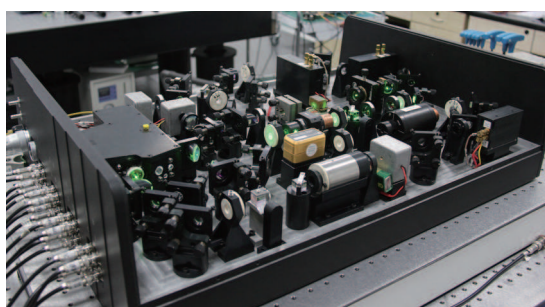

Fig. 3. (color online) Photograph of the entangled light source. The breadboard dimensions are 60 cm \times 50 cm. The total weight of the system is approximately 30 kg.

The fundamental wave at 1.08 μm from the pump laser is also used for the initial alignment of the NOPA, the measurement of its classical parametric gain, and the reference light for the cavity length control. The 1.08 μm laser reflected from the resonator is detected by a photodetector (PD2) and then an error signal at a modulation frequency of 60 MHz is generated via the Pound–Drever–Hall (PDH) technique (NOPA locking in Fig. 2).^[27] The electronic error signal is fed back

to PZT5 mounted on the NOPA output mirror to control the cavity length.

Another control circuit (π phase locking in Fig. 2) is utilized to actively lock the relative phase between the pump laser a^{P} and the seed wave a^{in} . For the phase locking, a signal of 38 kHz is modulated on the pump laser by PZT4 and the error signal is extracted from the output signal of a high gain photodetector (PD4) by means of the standard lock-in technique.^[9] The error signal is then fed back to PZT3 placed at the path of the seed wave to lock the relative phase between the pump laser a^{P} and the injected light a^{in} to $(2n + 1)\pi$.

To conveniently measure the quantum correlations of the produced output light a_1 and a_2 , a diagnostic module for Bell state detection is integrated on the source, which consists of three beam splitters, a half wave plate, two photodetectors, and a relative phase locking circuit ($\pi/2$ phase locking in Fig. 2) between the two entangled EPR beams. A flip mirror (FM) is installed at the exit of the NOPA to switch the transmission direction of the EPR beams to outside of the source for ap-

plications or into the diagnostic module for the entanglement detection. In the detection system, the two entangled beams a_1 and a_2 are separated by a polarizing beam splitter (PBS1) first and they are then combined again in a 50/50 beam splitter, which is constructed by two PBSs (PBS2 and PBS3) and a half wave plate. The interference phase of a_1 and a_2 on PBS2 can be changed by scanning PZT6 to control the difference of the optical paths between a_1 and a_2 . The two output beams c and d of PBS3 are injected into two high-gain detectors consisting of FD500W-1064 photodiodes (PD5 and PD6), respectively. An error signal is extracted from the direct current (DC) output of PD5 or PD6, which is fed back to PZT6 to lock the relative phase between a_1 and a_2 to $\pi/2$. The output alternating currents (AC) i_c and i_d of PD5 and PD6 are combined by a positive or a negative power combiner to produce the photocurrent i_+ of the amplitude sum $\langle \delta^2(X_1 + X_2) \rangle$, or i_- of the phase difference $\langle \delta^2(Y_1 - Y_2) \rangle$, respectively. Then, i_+ (i_-) is analyzed by an electronic spectrum analyzer to obtain the noise level of the anticorrelated amplitude (correlated phase) quadrature between the entangled beams a_1 and a_2 . When blocking the pump laser of the NOPA and locking the optical cavity to resonate with the seed wave at $1.08 \mu\text{m}$, the output of the NOPA is the coherent state of light at $1.08 \mu\text{m}$. Thus, in this case, when the output power exactly equals that of the entangled beams, the measured noise power of the amplitude (phase) quadrature corresponds to the shot noise limit.

4. Operational procedures and output characteristics

To utilize the source to generate the EPR entangled light and measure its quantum correlations, four procedures should

be carried out in order: 1) lock the frequency of the pump laser to the high-stability F-P cavity; 2) carefully adjust the temperature of the KTP crystal within the range of KTP phase-matching temperature to achieve the simultaneous resonance of a_1 and a_2 inside the NOPA, and then actively lock the cavity length of the NOPA to achieve stably double resonance of a_1 and a_2 ; 3) lock the relative phase between a^P and a^{in} to $(2n + 1)\pi$; and, 4) lock the relative phase between a_1 and a_2 in the detection module to $\pi/2$.

In the experiment, the intensity of the pump laser before the NOPA is 240 mW, which is 80% of its oscillation threshold of 300 mW. In this case, a parametric gain of 20 is reached. When the power of the seed wave injected into the NOPA is about 1 mW, the intensity of the output EPR entangled beams is $67 \mu\text{W}$ due to parametric deamplification. The detection efficiency and the interference efficiency of the detection system are 95% and 99.5%, respectively.

The measured quantum correlations of the entangled states at the analysis frequency of 2 MHz are shown in Fig. 4. Trace (i) represents the SNL obtained with a coherent light of $67 \mu\text{W}$, which delivers a large dark noise clearance of 11 dB. Traces (ii) in Figs. 4(a) and 4(b) are the measured correlation variances of the quadrature amplitude sum $\langle \delta^2(X_1 + X_2) \rangle$ and the quadrature phase difference $\langle \delta^2(Y_1 - Y_2) \rangle$, which are 5.1 ± 0.2 dB and 5.2 ± 0.2 dB below the corresponding SNL, respectively. The correlation variances satisfy the inseparability criteria for entanglement states in Ref. [28]; that is, $\langle \delta^2(X_1 + X_2) \rangle + \langle \delta^2(Y_1 - Y_2) \rangle = 0.62 < 2$. Considering the influence of the electronic noise in the detection module, the real quantum correlations of the generated EPR beams should be $\langle \delta^2(X_1 + X_2) \rangle = 6.4 \pm 0.2$ dB and $\langle \delta^2(Y_1 - Y_2) \rangle = 6.5 \pm 0.2$ dB below the SNL.

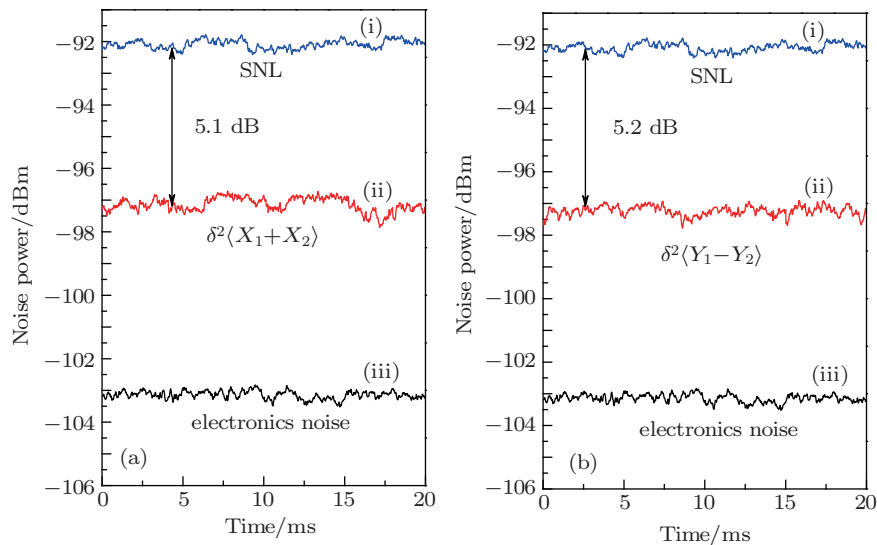

Fig. 4. (color online) The measured entangled light noise powers of (a) amplitude sum and (b) phase difference at 2 MHz: (i) shot noise limit, (ii) correlation noise, (iii) electronics noise. The RBW and VBW of spectrum analyzer are 39 kHz and 30 Hz, respectively.

5. Conclusion

We present a stable entangled light source that integrates the pump laser, entanglement generator, detectors, and electronic control systems. Based on the requirements of the NOPA, we design a single-frequency laser with suitable output power, which not only minimizes the size and the power consumption of the system but also reduces the laser noise. The pump laser reaches the quantum noise limit above 1.5 MHz. Therefore, it is not necessary to insert the MCs, which simplifies the EPR generator's configuration. By optimizing the optical path from the laser to the NOPA, the influence of the air disturbance is reduced. Finally, correlations over 6 dB can be directly provided by the entangled light source, and the total dimension, weight, and power consumption of the entangled light source are only 60 cm×50 cm, 30 kg, and 150 W, respectively. This compact and stable entangled light source is suitable for practical applications in quantum information science and technology. The presented protocol provides a useful reference for manufacturing products of bright entangled light sources.

References

- [1] Menicucci N C, Loock P V, Gu M and Weedbrook C 2006 *Phys. Rev. Lett.* **97** 110501
- [2] Deng L, Cheng A X and Zhang J S 2011 *Chin. Phys. B* **20** 110304
- [3] Su X L, Hao S H, Deng X W, Ma L Y, Wang M H, Jia X J, Xie C D and Peng K C 2013 *Nat. Commun.* **4** 2828
- [4] Madsen L S, Usenko V C, Lassen M, Phillip R and Andersen U L 2012 *Nat. Commun.* **3** 1083
- [5] He G Q and Zeng G H 2006 *Chin. Phys.* **15** 2252
- [6] Zhang Y Q, Jin X R and Zhang S 2006 *Chin. Phys.* **15** 2252
- [7] Jia X J, Su X L, Pan Q, Gao J R, Xie C D and Peng K C 2004 *Phys. Rev. Lett.* **93** 250503
- [8] Sheng Y B, Zhou L, Cheng W W, Gong L L, Zhao S M and Zheng B Y 2012 *Chin. Phys. B* **21** 030307
- [9] Martin A, Alibart O, Micheli M P, Ostrowsky D B and Tanzilli S 2012 *New J. Phys.* **14** 025002
- [10] Furusawa A, Sorensen J L, Braunstein S L, Fuchs C A, Kimble H J and Polzik E S 1998 *Science* **282** 706
- [11] Yonezawa H, Aoki T and Furusawa A 2004 *Nature* **431** 430
- [12] Zhang T C, Goh K W, Chou C W, Lodahl P and Kimble H J 2003 *Phys. Rev. A* **67** 033802
- [13] Reid M D and Drummond P D 1988 *Phys. Rev. Lett.* **60** 2731
- [14] Ou Z Y, Pereira S F, Kimble H J and Peng K C 1992 *Phys. Rev. Lett.* **68** 3663
- [15] Silberhorn C, Lam P K, Wei B O, Konig F, Korolkova N and Leuchs G 2001 *Phys. Rev. Lett.* **86** 4267
- [16] Bowen W P, Treps N, Schnabel R and Lam P K 2002 *Phys. Rev. Lett.* **89** 253601
- [17] Villar A S, Cruz L S, Cassemiro K N, Martinelli M and Nussenzveig P 2005 *Phys. Rev. Lett.* **95** 243603
- [18] Keller G, Auria V D, Treps N, Coudreau T, Laurat J and Fabre C 2008 *Opt. Express* **16** 9351
- [19] Zheng Y H, Wu Z Q, Huo M R and Zhou H J 2013 *Chin. Phys. B* **22** 094206
- [20] Eberle T, Handchen V and Schnabel R 2013 *Opt. Express* **21** 11546
- [21] Wang Y, Shen H, Jin X L, Su X L and C D Xie 2010 *Opt. Express* **18** 6149
- [22] Su X L, Zhao Y P, Hao S H, Jia X J, Xie C D and Peng K C 2012 *Opt. Lett.* **37** 5178
- [23] Vahlbruch H, Khalaidovski A, Lastzka N, Graf C, Danzmann K and Schnabel R 2010 *Class. Quantum Grav.* **27** 084027
- [24] Khalaidovski A, Vahlbruch H, Lastzka N, Graf C, Danzmann K, Grote H and Schnabel R 2012 *Class. Quantum Grav.* **29** 075001
- [25] Zhang J and Peng K C 2000 *Phys. Rev. A* **62** 064302
- [26] Chen H X and Zhang J 2009 *Phys. Rev. A* **79** 063826
- [27] Drever R W P, Hall J L, Kowalski F V, Hough J, Ford G M, Munley A J and Ward H 1983 *Appl. Phys. B* **31** 97
- [28] Duan L M, Giedke G, Cirac J I and Zoller P 2000 *Phys. Rev. Lett.* **84** 2722