

Ultra-Low Mean-Photon-Number Measurement with Balanced Optical Heterodyne Detection *

LI Gang(李刚), LI Li-Ping(李利平), DU Zhi-Jing(杜志静), LIU Tao(刘涛),
ZHANG Tian-Cai(张天才)**, WANG Jun-Min(王军民)

*State Key Laboratory of Quantum Optics and Quantum Optics Devices, Institute of Opto-Electronics,
Shanxi University, Taiyuan 030006*

(Received 1 September 2003)

Determination of an ultra-low mean photon number is an important issue, either for precise optical measurement or understanding the interaction between individual atoms and photons inside an optical cavity. By utilizing a homemade balanced optical heterodyne detection system, the cw minimum measurable power of 3.6 fW has been reached, whereas the minimum mean photon number of $\langle n \rangle = 0.0014$ in our micro-cavity with finesse of 2×10^5 and optical length of 48 mm can be realized.

PACS: 42.79.-e

Optical heterodyne detection (HD) has been widely used in various fields due to its ultra-sensitivity, such as optical measurement (for example, the gravity-wave detection^[1]), communication,^[2] laser spectroscopy,^[3] optical image,^[4] memory,^[5] and optical material research,^[6] etc. It is also used in quantum optics for the measurement of quantum states,^[7] single-shot phase of single-mode pulse,^[8] quantum noise measurement,^[9] etc. On the other hand, measurement of ultra-low optical field, which can be helpful to understand the optical losses or to monitor the atom-field interaction process in real time,^[10] is not a trivial problem. In this Letter, we report the measurement ultra-low optical power with a homemade balanced optical heterodyne detection. The cw minimum measurable power of 3.6 fW has been reached, which corresponds the minimum mean photon number of $\langle n \rangle = 0.0014$ in our super-microcavity with finesse of 2×10^5 and optical length of 48 μm .

The basic idea of balanced HD is to apply a strong local beam to amplify the weak signal. The amplitudes of signal and local beams on the BS can be written as $V_s = \sqrt{I_s} \exp i[\omega_0 t + \varphi_s(t)]$ and $V_{LO} = \sqrt{I_{LO}} \exp i[(\omega_0 + \Delta\omega)t + \varphi_{LO}(t)]$, ω_0 is the frequency of signal. I_{LO} , I_s and $\varphi_{LO}(t)$, $\varphi_s(t)$ are the intensities and the phases of the signal and local beams, respectively; $\Delta\omega$ is the frequency difference between them. By assuming $\varphi(t) = \varphi_{LO}(t) - \varphi_s(t)$, the subtraction output of the two detectors can be expressed in the form of

$$i(\omega) = \sqrt{I_s I_{LO}} \cos(\omega - \Delta\omega), \quad (1)$$

where $\varphi(t)$ is the phase difference between the signal and local beams, which fluctuates due to the mechanical vibration and air flowing in the actual ex-

periments. However, this fluctuation of optical length difference does not significantly affect the beat note signal (BN) at $\Delta\omega$ since the vibration of the phase difference is very slow compared with the frequency of 80 MHz, where we have made the measurements. It is well known that the typical frequency of mechanics is 1 kHz. If we assume the optical length changes 2π with a sine wave, the calculation shows that the influence on beat note signal is less than 10^{-4} , which is negligible. Equation (1) can be given in frequency domain as

$$i(\omega) = \sqrt{I_s I_{LO}} \delta(\omega - \Delta\omega). \quad (2)$$

The BN (in units of dB) at frequency $\Delta\omega$:

$$BN \propto 0.5 \log_{10} I_s + 0.5 \log_{10} I_{LO}, \quad (3)$$

which is linear with denary logarithm of the signal power.

Figure 1 shows the experimental setup. The single-mode cw external grating feedback diode laser (SDL-5412), operated at 848 nm, is temperature controlled within 0.005 deg. An optical isolator with 40 dB of isolation is used after the collimated and reshaped beam. An electric optical modulator (Linos LM 0202) is used as an amplitude modulator for balancing the two arms of the HD at the frequency at which we obtain the beat note signal. A polarization beam splitter creates two beams: the strong beam is the local oscillator whereas the tiny beam is sending to an AOM (Crystal Technology 3080-122), which is driven by an rf synthesizer at 79.9 MHz, yielding a very weak frequency-up-shifted light as the signal beam. The local beam and the signal beam combined on the 50/50 beam splitter.

* Supported by the National Natural Science Foundation of China under Grant Nos 60178006, 69928504, and 10374062, the TRAPOYT in Higher Education Institutions of MOE, and Research Funds for Returned Scholar Abroad and Youth from Shanxi Province (No 20031002).

** To whom the correspondence should be addressed. Email: tczhang@sxu.edu.cn

©2004 Chinese Physical Society and IOP Publishing Ltd

The half-wave plates on the optical path are used to control the intensity and polarization of the beams. D_1 and D_2 (Hamamatsu S5972) are a pair of home-made photo-detectors and the rf amplifiers collect the light emerging from the two ports. The difference of their photocurrents provides the beat note signal, which is proportional to the intensity of the signal beam. The beat note signal is measured by a spectra analyser (Agilent-E4411B).

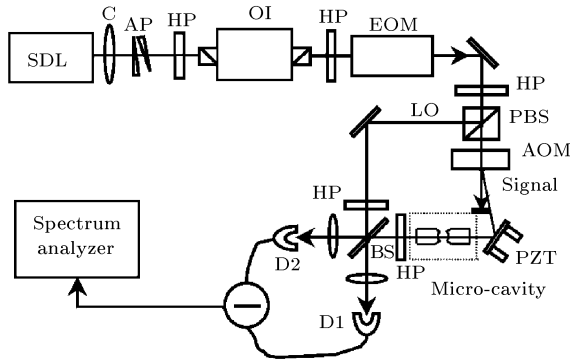

Fig. 1. Experiment setup. SDL: SDL diode laser; C: collimator; OI: optical isolator; HP: half-wave plates; PBS: polarization beam splitting cube; EOM: electro-optic modulator; AOM: acoustic-optical modulator; BS: beam splitter; D_1 and D_2 : photodetectors; SA: spectrum analyser.

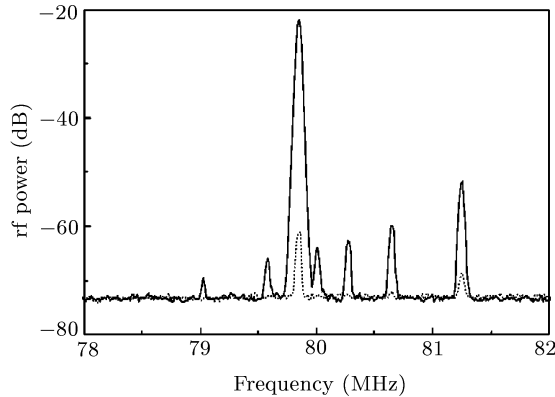

Fig. 2. Common mode rejection at 79.7 MHz. Solid: single-arm signal; dotted: double-arm signal.

In order to improve the spatial mode-matching between the signal and local beams, a piezoelectric transducer is used to scan the phase of the signal and to optimize the overlap efficiency by measuring the visibility of interference between signal (zero-order of the AOM) and local beam. The measured interference visibility is about 85%. An rf amplitude modulation at 79.9 MHz drives the optical modulator and we show the result of common mode rejection of the balance detection in Fig. 2. The solid line represents the signal when one of the beams to the photo-detector is blocked (single-arm signal) and the dotted line represents the signal when both arms are

unblocked (double-arm signal). It is clear that the common mode rejection is about 40 dB at 79.7 MHz and in this case the technical noise of the local light can be dramatically suppressed.

The total heterodyne efficiency is limited by the quantum efficiency of the detector and the overlap efficiency and it can be determined by the following expression in experiment:^[11]

$$\varepsilon = D \frac{E_{\text{phot}}}{P_t} B, \quad (4)$$

where D is the power ratio of the beat note power in the calibrating beam to the power in the shot noise for photo-current, B is the detection bandwidth in units of Hz, E_{phot} is the energy of single photon at the measured wavelength (848 nm), and P_t is the signal power, 37% of heterodyne efficiency in our experiment is obtained. Figure 3 shows a typical beat note signal where the signal is 69 nW and the local power is 2.8 mW, at which the power supply to the photo-detectors is about 3 dB of the shot noise over the electronic noise in the difference photocurrent around 80 MHz. The dotted line represents the electronic noise and the dashed line denotes the shot noise of the local light whereas the solid line is the beat note signal.

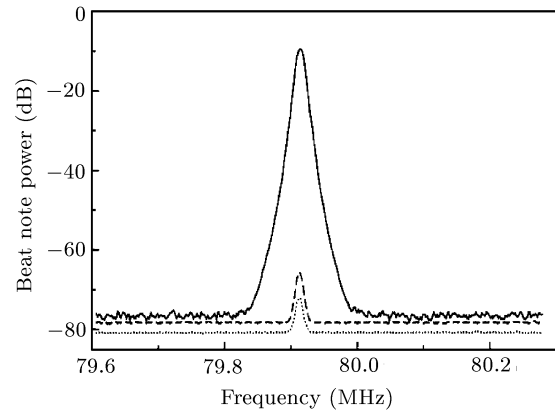

Fig. 3. Beat note level at 69 nW of signal power and 2.8 mW of the LO power with the measured central frequency 79.9 MHz, resolution bandwidth (RBW) 10 kHz and video bandwidth 100 Hz. Solid: beat note signal, dashed: shot noise level, dotted: electronic noise level.

We have measured the beat note when we vary the signal from 9 nW to nearly a hundred of nanowatts. Figure 4 is the normalized beat note signal (zero dB corresponds to the shot noise of the local beam) versus the signal power. Obviously, the beat note power is proportional to the signal. The fit line gives

$$BN = 52.6 + 9.67 \times \log_{10} P_{\text{signal}}, \quad (5)$$

where BN is the beat note power in units of dB, and P_{signal} is the input signal in units of nanowatts. It gives the minimum measurable power based on our

system, 3.6 fW, corresponding to $SNR = 1$ (0 dB in Fig. 4). Theoretically, the minimum power detected is^[12]

$$(P_s)_{\min} = h\nu B/\eta_q, \quad (6)$$

where h is Planck's constant, ν is the laser frequency, B is the bandwidth, and η_q is the quantum efficiency of the photo-detectors. The minimum detected power in an ideal case given by Eq. (6) is 3.1 fW. The discrepancy is most likely due to the imperfection of the overlap between the local and signal beams and the residual electronic noise.

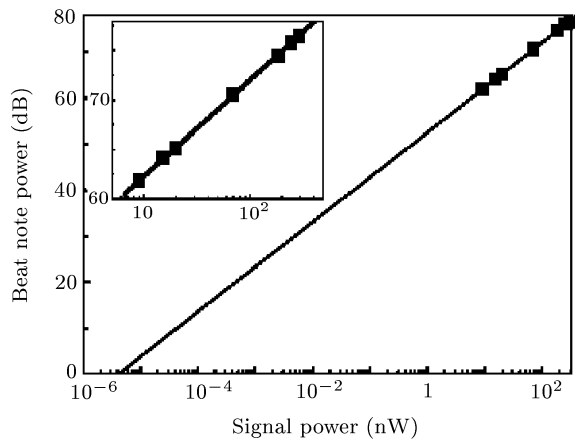

Fig. 4. Beat note power versus signal power. The fitted line is obtained by $BN = 52.6 + 9.67 \times \log_{10} P_{\text{signal}}$, which gives the minimum detectable power of 3.6 fW.

The system can be used to measure the very weak light field and very low mean photon number in a super-microcavity. The way to do this is to put a super-microcavity on the signal path (dashed box shown in Fig. 1) and the transmission of the cavity is as the signal beam. We have built such a cavity with super-mirrors (Research Electro-Optics, Inc.). The length of the cavity is fixed by direct measurement of the free spectra range and it gives $l = 48 \mu\text{m}$. Figure 5 shows the measured transmission of the super-microcavity and the cavity finesse of $F = 2.03 \times 10^5$. Thus, the total losses of the end-mirror is $L_2 = T_2 + S_2 = 1.5 \times 10^{-5}$. We assume the extra-losses of the mirror are neglectable, and then the transmission of the end mirror is $T_2 = 1.5 \times 10^{-5}$.

We suppose that the intracavity mean photon number is $\langle n \rangle$, then the output photon flux per second is

$$M = T_2 \langle n \rangle \frac{c}{2l}, \quad (7)$$

where c is the speed of light in vacuum. The corresponding power is then

$$P_{\text{out}} = ME_{\text{phot}}. \quad (8)$$

Figure 6 shows the simulated result of relation between the mean photon number and the beat note

power based on our system. The mean photon number can be determined by measuring P_{out} and the minimum mean photon number corresponding to the above-mentioned minimum detectable power is $\langle n \rangle_{\min} = 0.0014$ based on our super-microcavity and HD system.

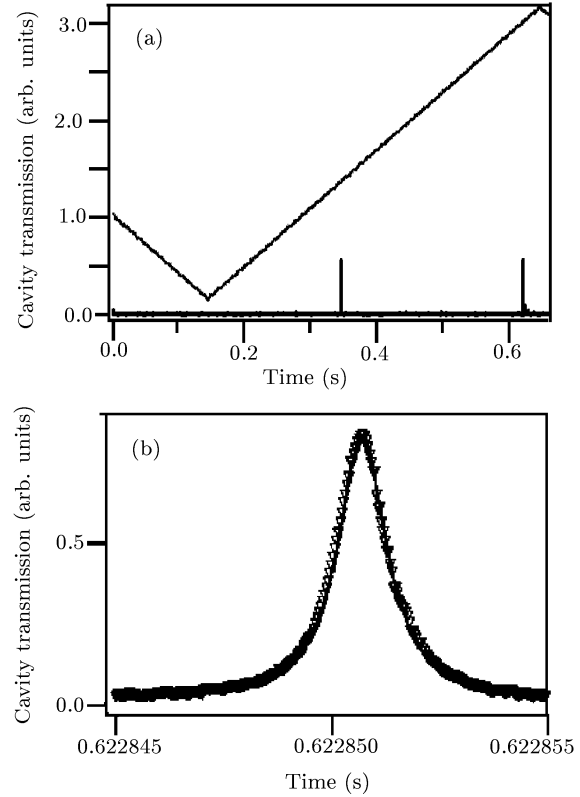

Fig. 5. Transmission of the super-microcavity. (a) The free spectra with the range of 0.2744 s (corresponding to 3.08×10^{12} Hz) when the cavity is scanned by a triangle wave. (b) The close look of the transmission peak. The solid line in (a) is the Lorentz fitting with the resulted FWHM of $1.35 \mu\text{s}$ (corresponding to 15.15 MHz). The finesse of the cavity is $F = 2.03 \times 10^5$.

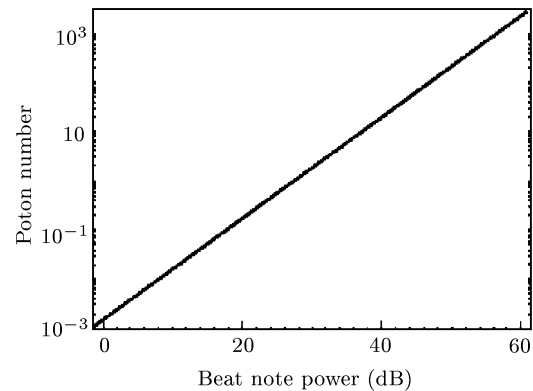

Fig. 6. Intracavity mean photon number versus beat note power based on the system.

In conclusion, we have carried out a balanced heterodyne detection system. The minimum detected power is 3.6 fW. With this HD system and the supermicrocavity, the detectable intracavity mean-photon-number can be reached 0.0014. This system can be used for ultra-low light field measurement and monitoring the interaction between individual atoms and photons in cavity quantum electrodynamical experiment.

References

- [1] Sun K X, Fejer M M, Gustafson E and Byer R L 1996 *Phys. Rev. Lett.* **76** 3053
- [2] Kuri T and Kitayama K 2002 *J. Commun. Res. Lab.* **49** 45
- [3] Westbrook C I, Watts R N, Tanner C E, Rolston S L, Phillips W D and Lett P D 1990 *Phys. Rev. Lett.* **65** 33
- [4] Kempe M, Genack A Z, Rudolph W and Dorn P 1997 *J. Soc. Am. A* **14** 216
- [5] Lin H, Wang T, Wilson G A and Mossberg T W 1995 *Opt. Lett.* **20** 928
- [6] Liu Q M, Mi J, Qian S X and Gan F X 2002 *Chin. Phys. Lett.* **19** 575
- [7] Laconis C, Mukamel E and Walmsley I A 2000 *J. Opt. B: Quantum Semiclass. Opt.* **2** 510
- [8] D'Ariano G M, Kumar P, Macchiavello C, Maccone L and Sterpi N 1999 *Phys. Rev. Lett.* **83** 2490
- [9] Paris G M A 1996 *Phys. Rev. A* **53** 2658
- [10] Wiseman H M and Killip R B 1997 *Phys. Rev. A* **56** 944
- [11] Li Y Q, Guzun D, Xiao M 1999 *Phys. Rev. Lett.* **82** 5225
- [12] Mubuchi H, Turchete Q A, Champman M S and Kimble H J 1996 *Opt. Lett.* **21** 1393
- [13] Hood C J, Champman M S, Lynn T W and Kimble H J 1998 *Phys. Rev. Lett.* **80** 4157
- [14] Yariv A 1976 *Introduction to Optical Electronics* 2nd edn (Holt, Rinehart & Winston) p 278