

Generation of a squeezed state at 1.55 μm with periodically poled LiNbO_3 *

Liu Qin(刘勤), Feng Jin-Xia(冯晋霞)[†], Li Hong(李宏),
Jiao Yue-Chun(焦月春), and Zhang Kuan-Shou(张宽收)

State Key Laboratory of Quantum Optics and Quantum Optics Devices,
Institute of Opto-Electronics, Shanxi University, Taiyuan 030006, China

(Received 18 January 2012; revised manuscript received 20 March 2012)

We report on the generation of a squeezing vacuum at 1.55 μm using an optical parametric amplifier based on periodically poled LiNbO_3 . Using three specifically designed narrow linewidth mode cleaners as spatial and noise filter of laser at 1.55 μm and 775 nm, the squeezed vacuum of up to 3.0 dB below the shot noise level at 1.55 μm is experimentally obtained. This system is compatible with standard telecommunication optical fiber, and will be useful for continuous variable long-distance quantum communication and distributed quantum computing.

Keywords: squeezed states, telecommunication wavelength of 1.55 μm , optical parametric amplifier

PACS: 42.50.Dv, 42.50.Lc, 42.65.Yj

DOI: 10.1088/1674-1056/21/10/104204

1. Introduction

Continuous variable (CV) quantum states of light at the wavelength of 1.5 μm have recently been focused on as a very interesting topic.^[1–3] The squeezed states of light at this wavelength can be transmitted with the lowest decoherence characteristic in a traditional silica-based telecommunication glass fibers due to the fact that its optical loss is as low as 0.2 dB/km.^[4] Moreover, the sensitivity of the interferometer can be improved a lot when the detector is driven by the light at a wavelength of 1.5 μm .^[5,6]

In the previous years squeezed light around 1.5 μm has been generated in the pulsed laser regime^[7–9] because there is no good quantity continuous-wave (cw) laser at 1.5 μm for quantum experiment. In 2008, 2.4-dB cw squeezed vacuum state at 1.5 μm was reported by using an Er-doped fiber amplifier seeded by a single-frequency laser diode.^[1] After that 5.3-dB cw squeezed vacuum state was generated by using a fiber laser at 1550 nm based on periodically poled potassium titanyl phosphate (PPKTP) crystal.^[2] However the fiber laser exhibits large excess noise above shot noise level (SNL)^[10] it can reduce the quantum characteristics of the nonclassical states of light in quantum optical experiment. So far, an

optical parametric amplifier (OPA) has been verified to be the most successful technique to generate cw quantum states of light (squeezed states of light or entangled states of light) with high quality^[11,12]

In the present paper, we report on the generation of cw vacuum squeezed state at 1.55 μm using an OPA containing a periodically poled lithium niobate (PPLN) crystal. The pump source of the OPA is the output from the external cavity enhanced second-harmonic generation (SHG), injected by a cw single frequency fiber laser. With the help of three narrow linewidth mode cleaners (MC) as spatial and noise filter of laser at 1.55 μm and 775 nm, the squeezed vacuum of up to 3.0 dB below the SNL at 1.55 μm was experimentally observed

2. Experimental setup

A schematic diagram of the experimental setup is shown in Fig. 1. A commercially erbium fiber laser (NP Photonic Inc.) provided about 2.0 W of cw single-frequency radiation at 1.55 μm . An optical isolator (OI) was used to eliminate the back-reflection light. The half wave plates (HWP) were used to control the polarization of laser beam. The laser beam was sent

*Project supported by the National Natural Science Foundation of China (Grant No. 60878003), the Science Foundation for Excellent Research Team of the National Natural Science Foundation of China (Grant No. 61121064), and the National Basic Research Program of China (Grant No. 2010CB923101).

[†]Corresponding author. E-mail: fengjx@sxu.edu.cn

© 2012 Chinese Physical Society and IOP Publishing Ltd

<http://iopscience.iop.org/cpb> <http://cpb.iphy.ac.cn>

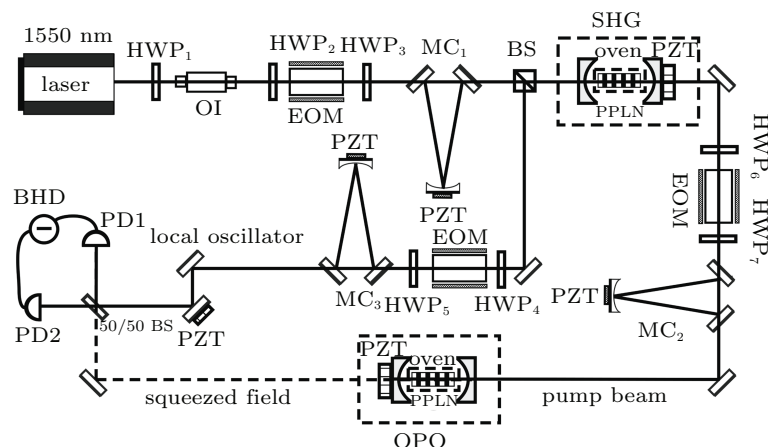

Fig. 1. Schematic diagram of the experimental setup. OI: optical isolator; EOM: electro-optical modulator; HWPs: half wave plate; MCs: mode cleaners; BS: beam splitter; PDs: photo diode; BHD: balanced homodyne detector; PZT: piezo-electric transducer.

through a ring MC1 cavity with a finesse of 180 and a linewidth of 2.0 MHz as a preliminary spatial and noise filter. An electro-optical modulator (EOM) with the radio frequency (RF) of 35 MHz was employed to lock the MC1 cavity using the Pound-Drever-Hall (PDH) technique^[13]. The main portion of output from MC1 was injected into the external enhanced SHG cavity to obtain a high-power low-noise cw laser at 775 nm that acted as the pump source of the OPA. The residual light was used separately as the signal beam of an OPA and the local oscillator (LO) of the balanced homodyne detector.

The external enhanced SHG cavity was a linear cavity composed of two curvature mirrors with a radius of 30 mm and a PPLN crystal. The input coupler had partial reflection for fundamental ($T_{1.55 \mu\text{m}} \sim 6.0\%$) and high reflection (HR) for second-harmonic (SH) ($R_{775\text{nm}} > 99.7\%$), and the output coupler had HR for fundamental ($R_{1.55 \mu\text{m}} > 99.7\%$) and partial reflection for SH ($T_{775 \text{ nm}} \sim 10.0\%$). The length of SHG cavity was 63 mm, resulting in a cavity waist of 69 μm for fundamental. The PPLN crystal had a dimension of 1 mm (thickness) \times 10 mm (width) \times 20 mm (length) with a poled period of 18.6 μm and both ends antireflectively coated at 1.55 μm and 775 nm, and was temperature controlled by a temperature controller with an accuracy of 0.01 $^\circ\text{C}$ (Model YG-2009B). The measured mode matching of the TEM₀₀ mode of fundamental beam to the external SHG cavity was 96% in the absence of MC1 cavity and it is 99% in the presence of MC1 cavity. When the PPLN crystal was at a temperature controlled at 130 $^\circ\text{C}$, 560 mW of SH power was obtained via

730-mW pumping power with 76% SH conversion efficiency. There was a 3% improvement of SH conversion efficiency owing to the spatial filtering of MC1. The MC2 with a linewidth of 1.0 MHz and MC3 with a linewidth of 16 MHz were used as the spatial and noise filters for 775-nm beam and LO and signal beam at 1.55 μm (the signal beam was omitted in Fig. 1), and locked using the PDH technique with the RF 65 MHz and 82 MHz respectively.

The OPA had the same structure and crystal parameters as the external enhanced SHG cavity. The input coupler had high transmission for pump ($T_{775 \text{ nm}} > 9.0\%$) and HR for down-conversion ($R_{1.55 \mu\text{m}} > 99.7\%$) and the output coupler had partial reflection for down-conversion ($T_{1.55 \mu\text{m}} \sim 6.0\%$) and HR for pump ($R_{775 \text{ nm}} > 99.7\%$). The length of OPA cavity was 63 mm, resulting in a cavity waist of 49 μm for pump. The signal beam was used for aligning the OPA and measuring the classical parametric gain. The down-conversion output from the OPA was separated from residual pump field by a dichroic beam splitter. The squeezed state was observed by a balanced homodyne detection system based on a pair of photodiodes (ETX-500 Epitaxx). The measured bandwidth of detectors was approximately 30 MHz, and the observed common noise rejection was 30 dB at analysis frequency of 2 MHz to 30 MHz.

3. Experimental results and discussion

The mode cleaners are employed for improving the characteristic of laser beam.^[14] The better spa-

tial mode of the pump beams contributes to better mode matching to SHG and OPA cavities, and to the next step for enhancing nonlinear conversion efficiencies in SHG and OPA processes. In addition, the MC reduces the intensity noise of the laser beam, which is more important for quantum optical experiment. When the MC1 is locked using the PDH technique, the intensity noises of laser before the MC1 and after the MC1 are measured using a self-balanced detection system^[15] and recorded by a spectrum analyzer (N9010A, Agilent) with a bandwidth resolution of 100 kHz, a video bandwidth of 100 Hz, and a sweep time of 1.5 s. The intensity noise of the fiber laser before the MC1 is more than 20 dB above the SNL from the analysis frequency of 2 MHz to 20 MHz, and it reaches the SNL at an analysis frequency of 15 MHz after the MC1. The SNL is calibrated by a thermal white light source. The power transmission of the MC1 is 60%. The noise characteristic of output from MC1 is not suitable for the quantum experiment, but the filter of MC1 will be the base of the second filter. The intensity noises of laser before the MC2 (that was the output of SHG) and after the MC2 (that was the pump of OPA) are also measured using the same system when the MC2 is locked. The intensity noise power spectrum is shown in Fig. 2, the sum signal gives the intensity noise power of the 775-nm laser (curves *b* and *c*) and the difference signal gives the SNL (curve *a*). It can be seen that the intensity noise of the pump of OPA reaches the SNL at an analysis frequency of 4 MHz (curve *b* in Fig. 2), owing to the MC acting as a noise eater, but the intensity noise of the output of SHG (curve *c* in Fig. 2) exhibits a large excess noise above the SNL till the analysis frequency of 15 MHz. The electronic noise level of the self-balanced detector is 10 dB below the SNL (not shown in Fig. 2).

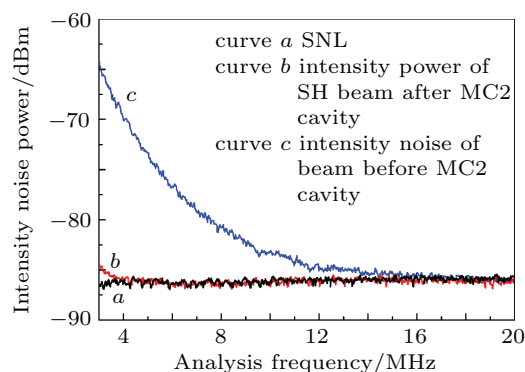

Fig. 2. Measured intensity noise power spectra of 775-nm laser before and after the MC2 cavity.

When the MC3 is locked, and the intensity noise of laser after the MC3 (that is the LO and signal beam at 1.55 μm) is measured and recorded by the same system. Figure 3 shows the intensity noise power spectrum. Curves *a* and *b* in Fig. 3 give the SNL and the intensity noise power of the 1.55- μm laser. It can be seen that the intensity noise of the LO and signal beam at 1.55 μm reaches the SNL at an analysis frequency of 5 MHz.

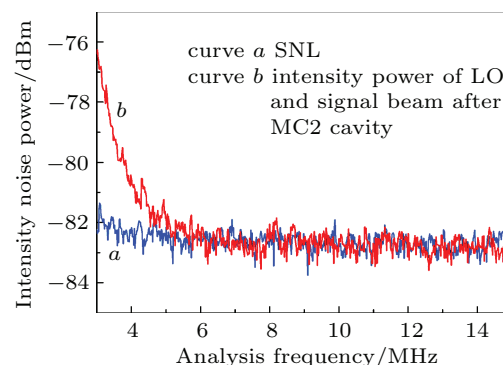

Fig. 3. Measured intensity noise power spectra of 1.55- μm laser after the MC3 cavity.

The OPA is pumped by the output of SHG that is spatial noise filtered by the MC2. The measured pump threshold of OPO is 46 mW. A signal beam at 1.55 μm (omitted in Fig. 1) that is spatial and noise filtered by the MC3 is used to measure the classical parametric gain of OPA. The measured classical parametric gain is 80 at a pump power of 38 mW. In squeezing experiments, the interference contrast between the LO and the squeezed field on the 50/50 homodyne beam splitter (BS) is crucial. To adjust the visibility we inject signal beam through the HR back side of the OPA. This signal beam matches the OPA TEM₀₀ mode. The light that was transmitted propagated in the mode congruent to the mode to be squeezed and could be used to overlap with LO on the homodyne beam splitter. A fringe visibility of 99% is obtained.

When the OPA is operated below the threshold with a pump power of 38 mW and the signal is blocked, the noise power of the down-conversion output from the OPA is measured by the balanced homodyne detection system and recorded by a spectrum analyzer (N9010A, Agilent) at an analysis frequency of 5 MHz. The recorded noise power spectrum is depicted in Fig. 4. Trace *a* corresponds to the SNL which is measured by blocking the squeezing vacuum. Traces *b* and *c* are the recorded squeezing and anti-squeezing output when the homodyne phase angle is locked.

Trace d is the quadrature quantum noise converted from squeezing to anti-squeezing by linearly scanning the LO phase. The power of LO is 10 mW, the electronic dark noise of homodyne detector is 20 dB below the vacuum noise and is not subtracted from the data. The measured squeezed noise is (3.0 ± 0.2) dB below the SNL and anti-squeezed noise is (9.8 ± 0.2) dB above the SNL.

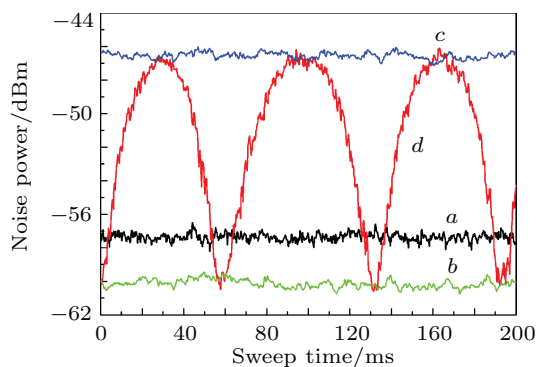

Fig. 4. Noise powers of the squeezed light at an analysis frequency of 5 MHz. The spectrum analyzer parameters: the resolution bandwidth 300 kHz and the video bandwidth 300 Hz. Trace a denotes the shot noise level; Traces b and c are squeezing and anti-squeezing curves, respectively; Trace d represents the measured quadrature quantum noise converted from anti-squeezing to squeezing by linearly sweeping the LO phase.

Our measurement is limited by the optical losses and the detection efficiency. There is an imperfect detection efficiency of 63% (including the detector quantum efficiency of 90%, the homodyne efficiency of 99%, the approximately escape efficiency of the OPA cavity of 90%, and the optical propagation efficiency of 84%). So the total loss of 37% reduces the squeezing once it is generated. In addition, the fluctuations of cavity lock-in and phase lock-in system are important restricting factors for improving the squeezed field. We expect that much higher squeezing level could be observed by optimizing optical system, searching better photodiode and reducing the lock-in fluctuation.

4. Conclusions

In this paper, we demonstrate (3.0 ± 0.2) dB squeezed vacuum at a telecommunication wavelength of $1.55 \mu\text{m}$ generated from a subthreshold cw pumped OPA with a PPLN crystal. The specifically designed narrow linewidth MC cavities are employed for filtering spatial mode and reducing the extra noise fluctuation of the pump fields. Squeezed vacuum states can

be used to enhance the sensitivity of the detection of gravitational waves, which is already realized with operating at 1064 nm .^[16,17] In the future, people would consider silicon as a test mass material and use the laser at $1.55 \mu\text{m}$ to reduce the thermal noise for higher signal-to-noise ratio. Furthermore, the EPR entangled states for CV at $1.55 \mu\text{m}$ can be obtained by a simple linear optical transformation of two squeezed vacuum fields, which are used in a variety of CV quantum communication and computing systems. At present, some entangled states are still not produced except so-called vacuum-class entanglement at $1.55 \mu\text{m}$ by mixing a squeezed mode with a vacuum mode.^[18]

References

- [1] Feng J X, Tian X T, Li Y M and Zhang K S 2008 *Appl. Phys. Lett.* **92** 221102
- [2] Mehmet M, Steinlechner S, Eberle T, Vahlbruch H, Thring A, Danzmann K and Schnabel R 2009 *Opt. Lett.* **34** 1060
- [3] Mehmet M, Eberle T, Steinlechner S, Vahlbruch H and Schnabel R 2010 *Opt. Lett.* **35** 1665
- [4] Miya T, Terunuma Y, Hosaka T and Moyashito T 1979 *Electron. Lett.* **15** 106
- [5] Rowan S, Hough J and Crooks D R M 2005 *Phys. Lett. A* **347** 25
- [6] Schnabel R, Britzger M, Brückner F, Burmeister O, Danzmann K, Dück J, Eberle T, Friedrich D, Lück H, Mehmet M, Nawrodt R, Steinlechner S and Willke B 2010 *J. Phys.: Conf. Ser.* **228** 012029
- [7] Silberhorn C, Lam P K, Wei O, König F, Korolkova N and Leuchs G 2001 *Phys. Rev. Lett.* **86** 4267
- [8] Eto Y, Tajima T, Zhang Y and Hirano T 2007 *Opt. Lett.* **32** 1698
- [9] Dong R, Heersink J, Corney J, Drummond P, Andersen U and Leuchs G 2008 *Opt. Lett.* **33** 116
- [10] Feng J X, Li Y M, Tian X T, Liu J L and Zhang K S 2008 *Opt. Express* **16** 11871
- [11] Wu L A, Kimble H J, Hall J L and Wu H 1986 *Phys. Rev. Lett.* **57** 2520
- [12] Vahlbruch H, Mehmet M, Chelkowski S, Hage B, Franzen A, Lastzka N, Goßler S, Danzmann K and Schnabel R 2008 *Phys. Rev. Lett.* **100** 033602
- [13] Drever R W P, Hall J L, Kowalski F V, Hough J, Ford G M, Munley A J and Ward H 1983 *Appl. Phys. B* **31** 97
- [14] Willke B, Uehara N, Gustafson E K, Byer R L, King P J, Seel S U and Savage R L 1998 *Opt. Lett.* **23** 1704.
- [15] Machida S and Yamamoto Y 1986 *IEEE QE-22* 617
- [16] Vahlbruch H, Chelkowski S, Hage B, Franzen A, Danzmann K and Schnabel R 2006 *Phys. Rev. Lett.* **97** 011101
- [17] Goda K, Miyakawa O, Mikhailov E E, Saraf S, Adhikari R, McKenzie K, Ward R, Vass S, Weinstein A J and Mavalvala N 2008 *Nature Phys.* **4** 472
- [18] Eberle T, Handchen V, Duhme J, Franz T, Werner R F and Schnabel R 2011 *Phys. Rev. A* **83** 052329